



REINFORCING YOUR IDEAS!

An idea must first take on concrete form before it can realize its full potential. We can support you by supplying textile composite materials made of carbon, glass, aramid and natural fibers for your light-weight construction applications. We offer perfectly coordinated processes and stable supply chains. Above all, we achieve this together with you – working in close cooperation.

SAERTEX is one of the world's leading manufacturers of precisely those materials that make you and your ideas stand out from the competition. Regardless of how your goals are defined. Do you want to effectively drive the energy revolution forward? Set new mobility concepts in motion? Perhaps sustainably optimize your composite application's performance? We understand what drives you. So let's talk about it!



FOUNDED

1982



SALES 2023 [€m]

275



EMPLOYEES [2023]

1,100



LOCATIONS
WORLDWIDE

14



CERTIFICATES

ISO 9001

ISO 14001

EN 9100

EcoVadis

QUALITY WITHOUT COMPROMISE

We believe that the highest quality standards are only just good enough. We therefore fulfill the requirements of EN 9100, a standard rooted in the aerospace sector, have established APQP4WIND quality assurance for our global wind power customers, and have certified all SAERTEX plants to ISO 9001 with the associated products certified to DNV-GL. However, the most important for us remains another test value: Your satisfaction.



DEVELOPED
COMPOSITE MATERIALS

> 3.333



VARIOUS
END APPLICATIONS

> 200

IT'S EASY TO FIND THE RIGHT MATERIAL

ONE-STOP SHOPPING

Multiaxial non-crimp fabrics made of glass, carbon or other fibers are our core technology. But SAERTEX offers you even more – for example SAERfoam for sandwich construction and LEO for fire protection. Our broad-ranging expertise and product diversity makes us your single point of contact for your composite reinforcement material needs.

MADE-TO-MEASURE MATERIAL SELECTION

We have the right material for whatever project you envisage. Thanks to our experienced application engineers and our in-house laboratory, we are quickly able to realize the ultimate material for your application at any time. The customized solutions from SAERTEX combine lightness, stability and cost-effectiveness: We have impressed our customers with over 3,333 customized SAERTEX products since 1982.

GREATER SUPPLY CHAIN EFFICIENCY

Our efficiency translates into your success factor. Our proven process chains ensure reliable delivery performance for you. Would you like to grow your volume business worldwide? Our team is there to serve you, with local production in eleven countries on five continents.

CONSERVING RESOURCES RESPONSIBLY

Our innovative materials facilitate a resource-conserving future – whether in the wind power, mobility or industrial segments. We are simultaneously helping to optimize our carbon footprint: We generate our own green electricity, recycle glass and carbon fiber waste into new products and keep transport routes to customers and suppliers as short as possible. This allows us to progress together in an increasingly sustainable manner.

OUR HIGH-TECH MATERIAL FOR LIGHTWEIGHT CONSTRUCTION

Lightness and durability are an unbeatable combination – and a strong argument for SAERTEX: Our technical textiles enable numerous industries to design components that are lighter, more durable and longer lasting.

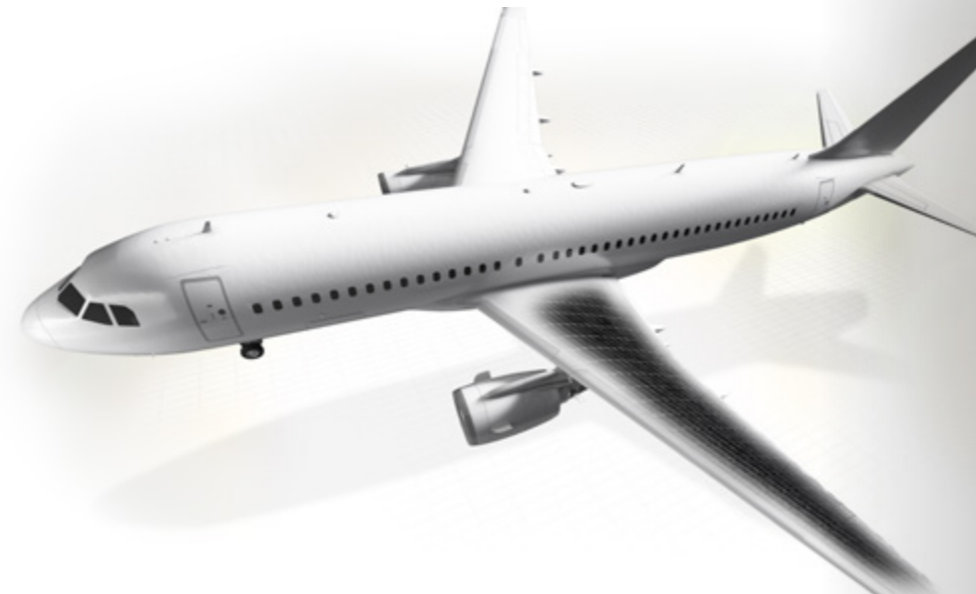
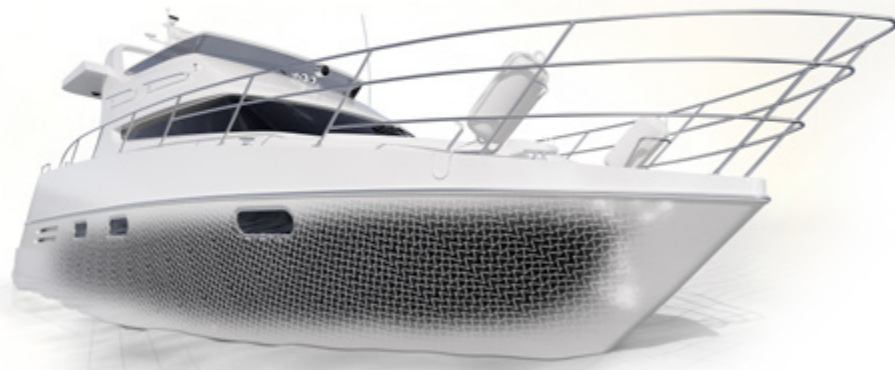

ON THE ROAD TO RAPID SUCCESS

The first SAERTEX customers included manufacturers of skis, snowboards and similar sports equipment. Materials from SAERTEX have found their way into many well-known sports brands, boat building and transportation companies.

We achieved another key milestone in 1996: The Blackwing project at McDonnell Douglas provided our entry into the aerospace industry with carbon fiber non-crimp fabrics (NCFs). We have since been steadily expanding our circle of prestigious clients in the aerospace industry. And we remain open to young companies offering innovative ideas for manned and unmanned aerial vehicles.



ACCELERATING THE ENERGY TRANSITION

The automotive industry has trusted SAERTEX as a reliable supplier of glass and carbon non-crimp fabrics for many years. Our developments continue to power e-mobility into the future: They serve, for example, to protect electric batteries, reduce weight, provide corrosion protection and offer impressively high energy efficiency.

We also have a productive partnership with the wind power industry: SAERTEX develops and supplies innovative materials for worldwide rotor blade manufacture. Our composite materials combine stiffness and strength with light weight – enabling extremely powerful and resilient rotor blades measuring over 100m in length.

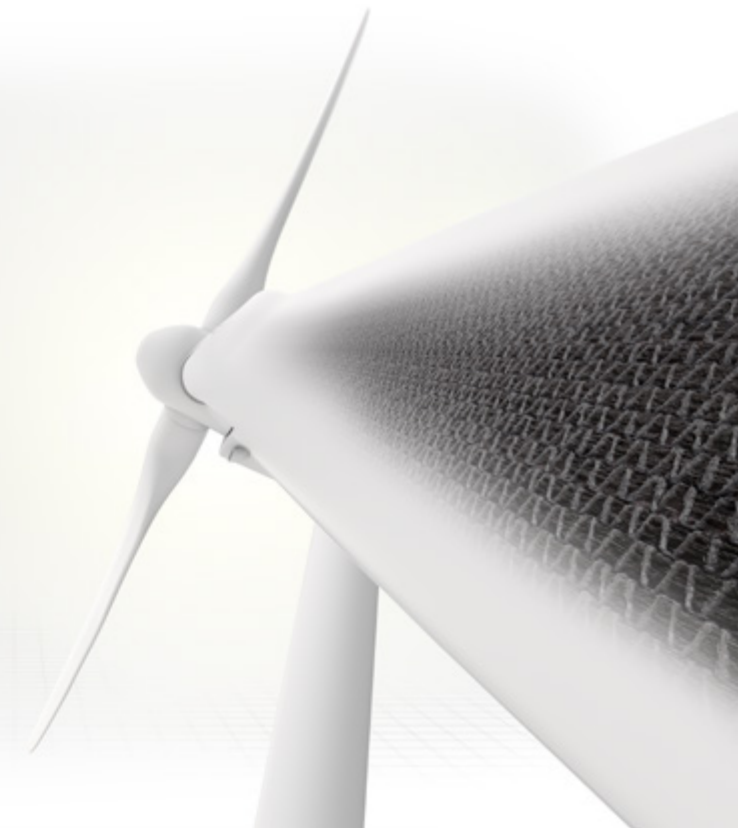

EXPLAINED AS SWIFT AS THE WIND: FROM FIBER TO COMPOSITE COMPONENT

SUPPLIER

SAERTEX

CUSTOMER

Our know-how in detail: This is our step-by-step guide to how a component made of fiber-reinforced composites is created. We will take a wind turbine rotor blade as an example

GLASS FIBER ROVING

Sand is smelted in furnaces. Thereby producing the glass fiber roving. By this we mean a strand of fiber filaments arranged in parallel. Sizing ensures the adhesion properties of the roving.

ROVING BECOMES NON-CRIMP-FABRIC

In multiaxial fabrics, the rovings are laid and not woven. This means that the fibers remain straight. In the next step, several layers are laid on top of each other at different orientations and sewn together to form a textile.

CARBON ROVING

Polyacrylonitrile- (PAN) based carbon fibers are produced via a carbonization process (at up to 1,800 °C). Up to 50,000 filaments (50k) are then combined to form a roving.

CORE MATERIALS FOR SANDWICH COMPONENTS

Some fiber composite components are not monolithic, but are produced as sandwich structures. For this purpose, lightweight polymer foams or balsa wood are used. The foam in SAERfoam is reinforced with glass fibers.

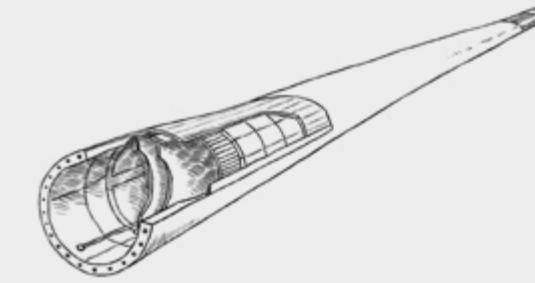
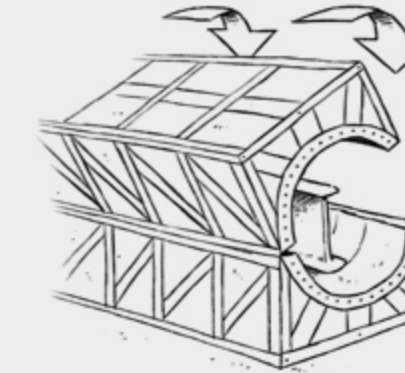
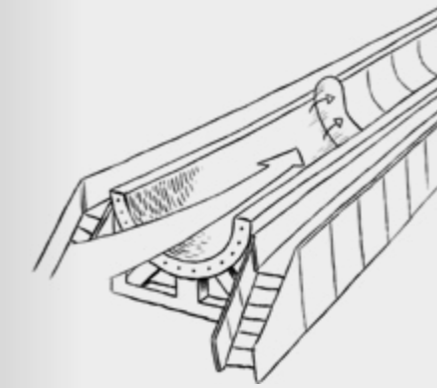
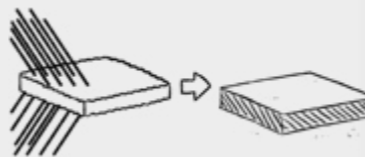
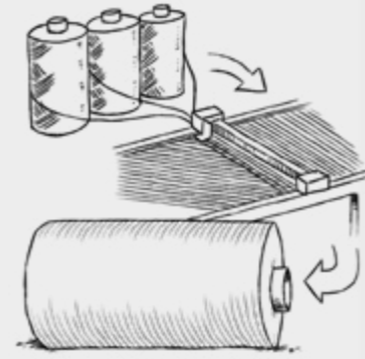

DRAPING IN THE MOLD

Manufacturing takes place primarily in the giant rotor blade molds. Cut-to-size non-crimp-fabrics are laid into the mold and smoothed out. In the process, special importance is attached to the drapability of the materials. At the same time, spar caps made of glass and carbon fiber UD's are used. SAERfoam, balsa or PET elements are then laid out over the entire surface. This is followed by further layers of multiaxial non-crimp-fabrics made of glass fibers.

FILM AND INFUSION WITH RESIN

The entire structure is covered with an airtight film. The vacuum infusion process then uniformly impregnates the layers beneath the film with resin.

CURING AND FURTHER STEPS

The fiber composite component is now allowed to cure. After curing, the plastic film is removed. The rotor blade is then further processed. The two halves are bonded together and the shear webs inserted. The blade is sanded and painted.

TO FINISHED ROTOR BLADE

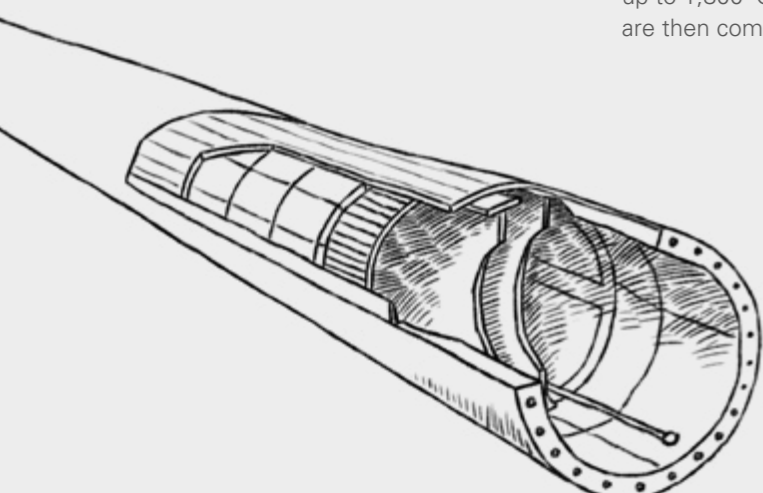

ONE-STOP SHOPPING – THE PERFECT TURNKEY SOLUTION!

An Efficient Decision

Make it easy for yourself with SAERTEX: We provide all of your composite reinforcement materials from a single source. Our core technology is non-crimp fabrics (NCFs) – for example made of glass, carbon or other fibers. We also offer you SAERfoam for sandwich construction and the SAERTEX LEO series for optimum fire protection.

Your benefits with SAERTEX:

- // Single point of contact
- // Single solution approach
- // Less time taken, greater transparency

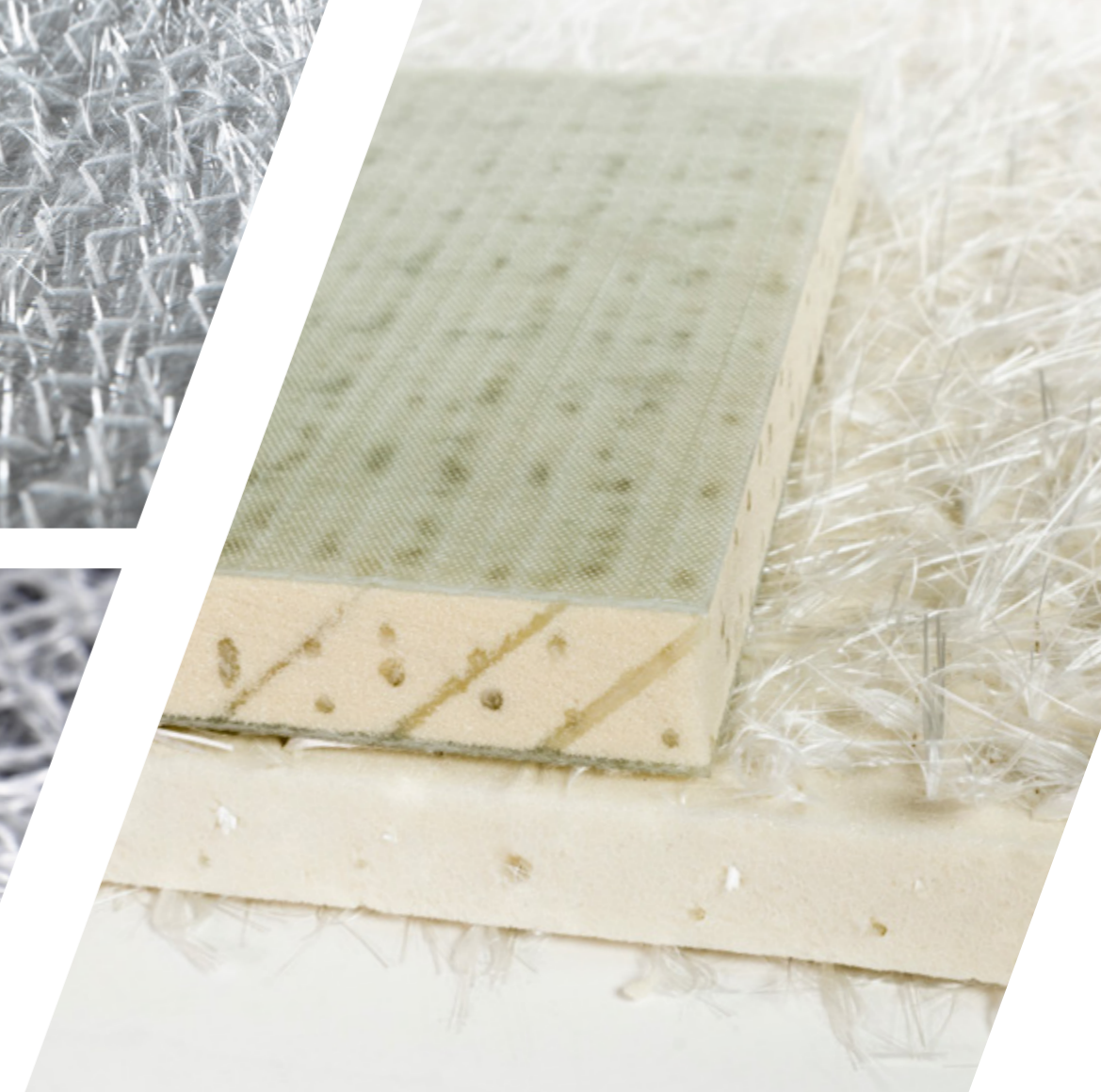
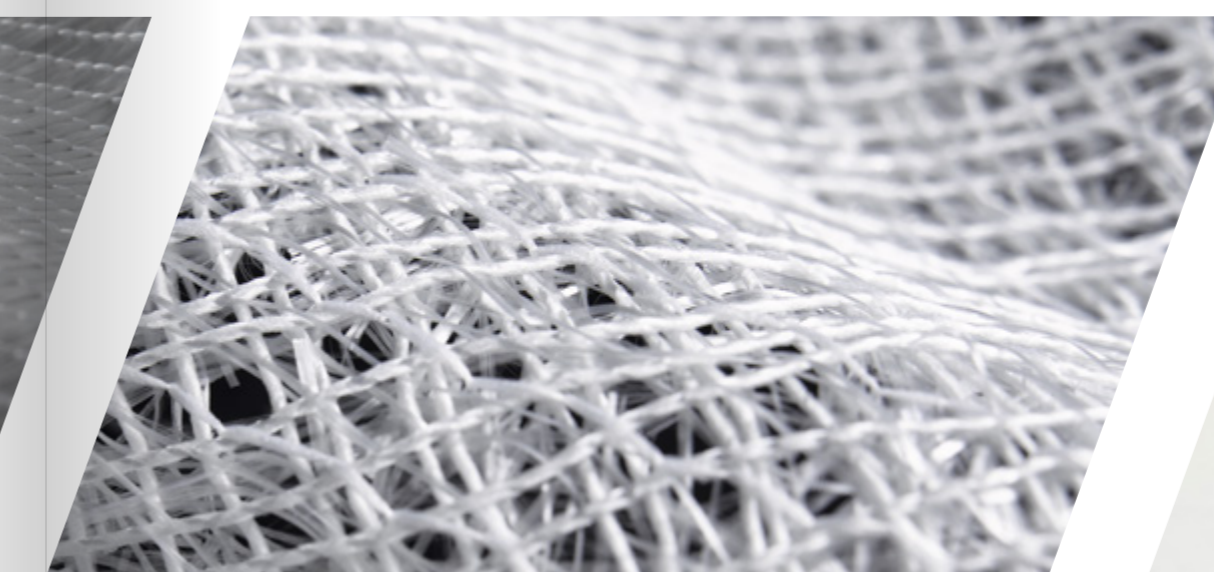
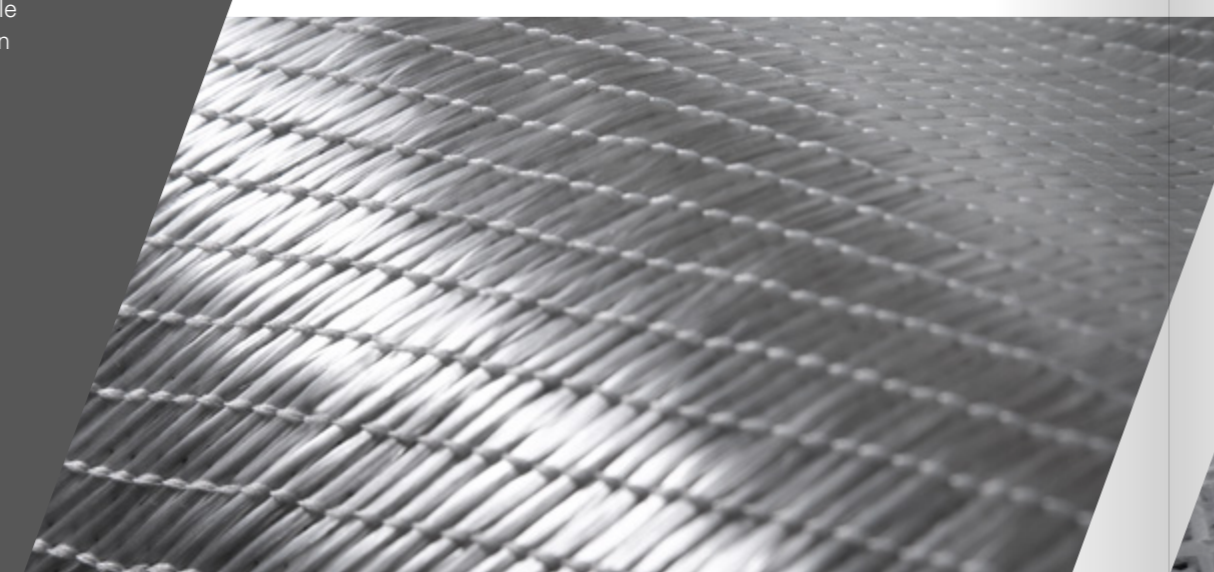

NON-CRIMP FABRIC

Textile reinforcing materials: Non-crimp fabrics made of glass, carbon, aramid and natural fibers for lightweight construction.

- // Multiaxial non-crimp fabrics
- // Unidirectional non-crimp fabrics
- // SAERcore
- // Product refinements such as flow aids

CORE MATERIALS

Our SAERfoam, with glass fiber reinforced foam for sandwich construction.

OUR NEW SAERcore®



WE FOCUS ON CONSERVING RESOURCES!

That's why we are constantly developing new solutions that combine efficiency and environmental awareness. Our new SAERcore® offers you real added value: a core made of 100 % recycled materials combined with excellent performance.

SAERcore® is a stitched or optionally bonded sandwich complex that consists of one or two layers of Chopped Strand Mat (CSM) and a core material (resin flow zone) in its basic version. The innovative "two-step impregnation" saves a considerable amount of time, because the integrated flow aid significantly accelerates resin injection across the entire width of the component.

It is a solution that sets new standards – for you and for the future.

1

Optimization of the core material:
100 % recycled material

2

Increased productivity:
Faster resin flow

3

Improved efficiency and handling:
Easier draping



Learn more about our new SAERcore

CARBON MINI TAPES

Our unidirectional materials deliver an application-oriented solution for the most demanding uses and tightest tolerances.

The ability to choose any desired carbon fiber content – and a flexible choice of widths from 1/4 inch – enables efficient processing with minimal material wastage.

The powder coating reinforces the fiber bond and specifically improves the material properties – especially when it comes to producing preforms.

They are particularly suitable for highly automated production processes such as fiber placement and are the ideal choice for infusion components with complex requirements.

1

Maximum precision for applications with tight tolerances

2

Efficient and automated processing for complex geometries

3

Minimized material losses



Learn more about our new Carbon Mini Tapes

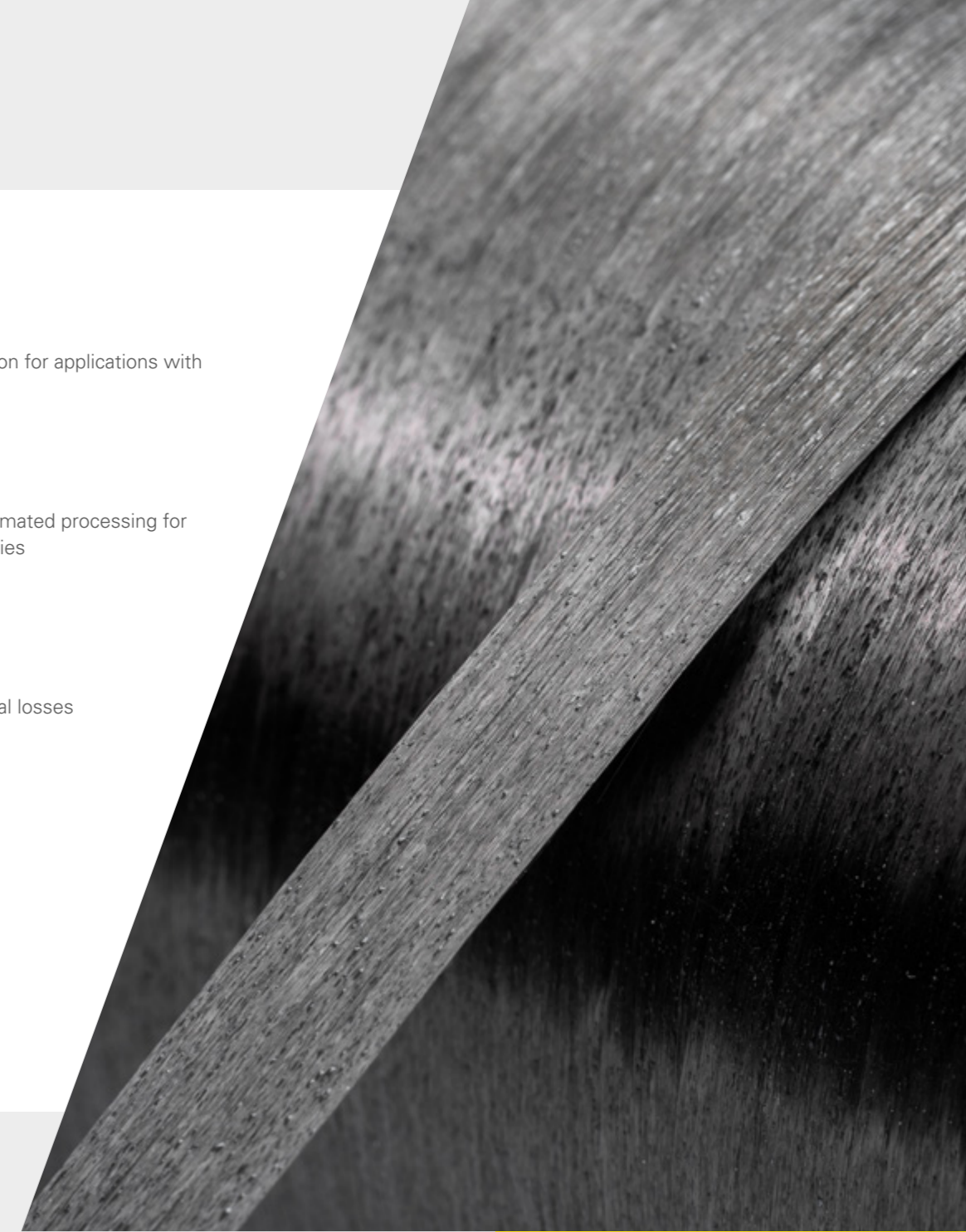

HERE YOU WILL FIND YOUR
REINFORCING MATERIAL

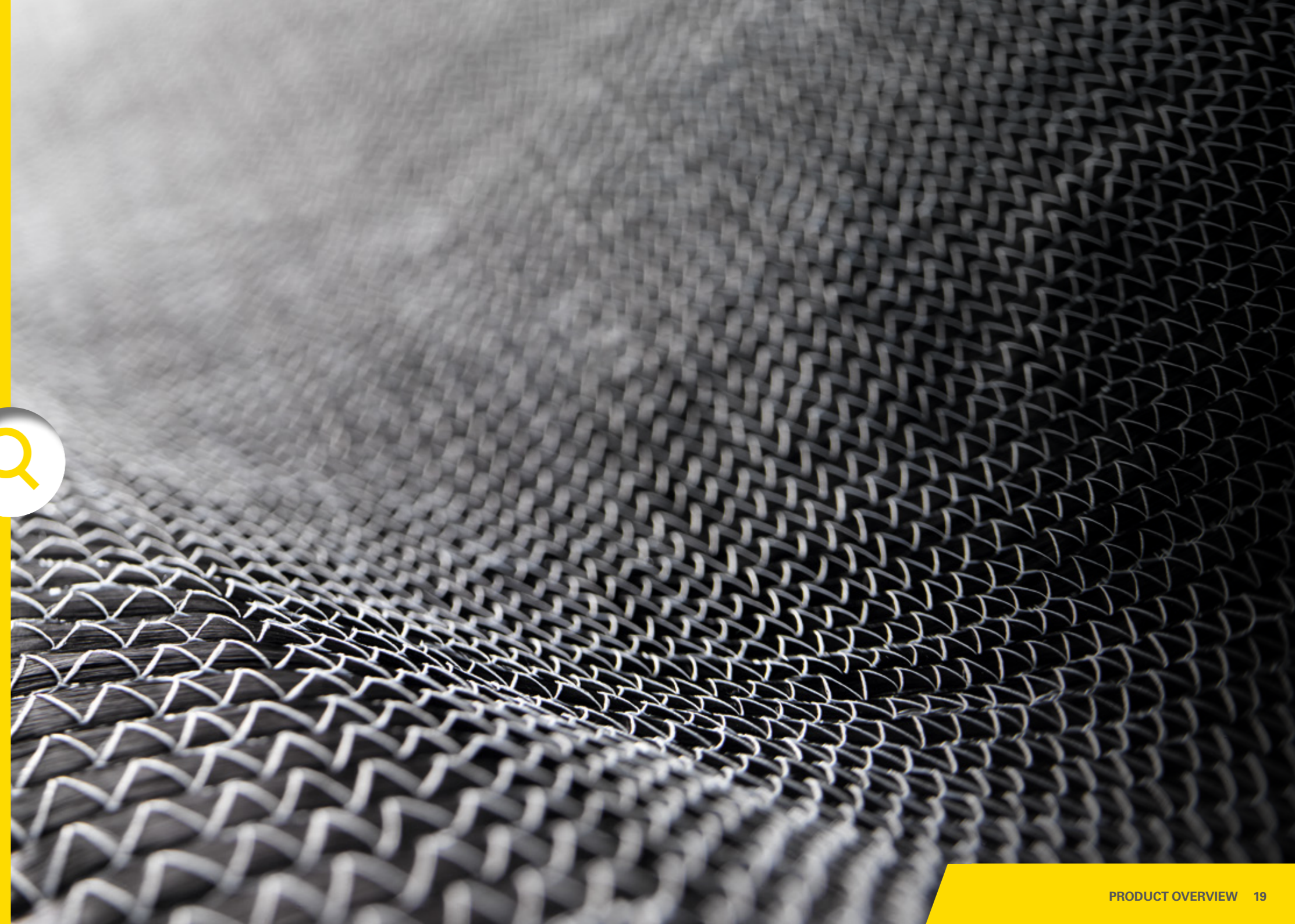

TREND SETTING: MULTIAXIAL NON-CRIMP FABRICS

How a Saertex Non-crimp Fabric Is Made:

The rovings are laid down without fiber undulations, thereby giving them a high mechanical load capacity. The special feature here is that it is possible to lay down multiple layers – with differing directional orientations. The individual layers are sewn together to form a textile reinforcing material.

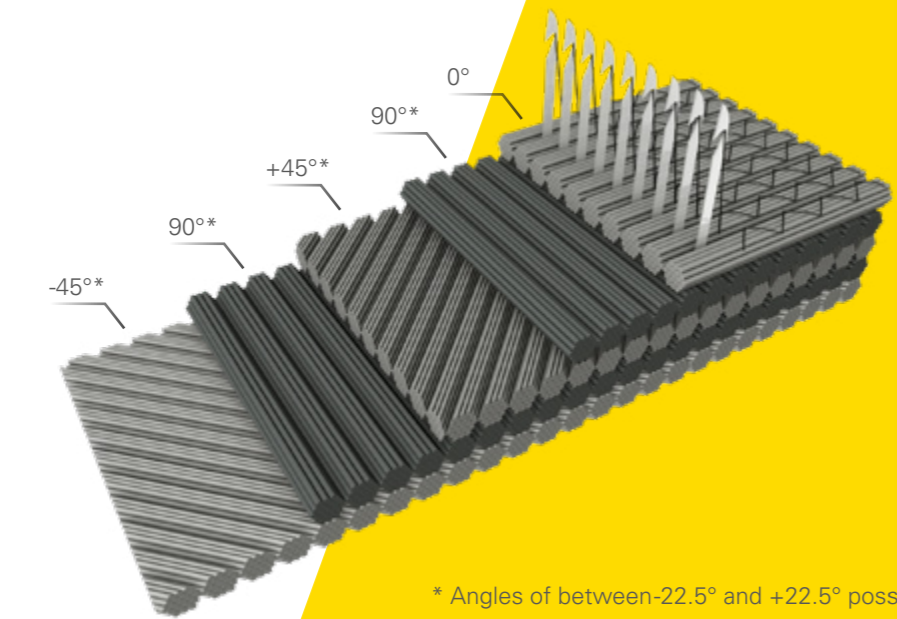

* Angles of between -22.5° and +22.5° possible.

UNDERLYING NON-CRIMP FABRIC STRUCTURES

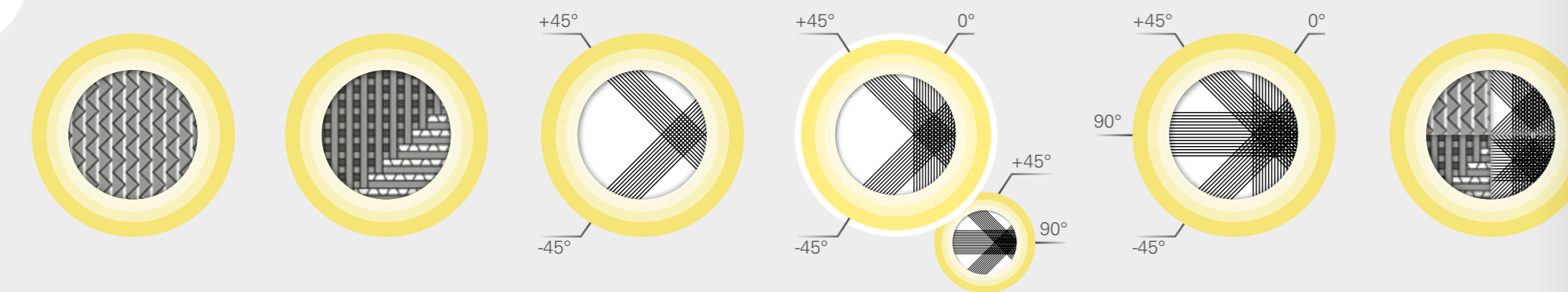

UNIDIRECTIONAL NON-CRIMP FABRIC
Structure: 0° or 90°

BIDIRECTIONAL NON-CRIMP FABRIC
Structure: 90°/0°

BIAXIAL NON-CRIMP FABRIC
Structure: ±45°

TRIAxIAL NON-CRIMP FABRIC
Structure: ±45°/0° or 90°/±45°

QUADRAxIAL NON-CRIMP FABRIC
Structure: ±45°/90°/0°

TAILOR-MADE NON-CRIMP FABRIC
Structure: Custom upon request

OUR PRODUCT RANGE

Over 3,333 Reinforcing Materials Made of Glass, Carbon, Aramid and Natural Fibers.

Product range	NON-CRIMP FABRIC			CORE MATERIAL
	UD/bidirectional	Multiaxial	SAERcore	SAERfoam
Material type	Textile reinforcement (dry)	Textile reinforcement (dry)	Textile reinforcement (dry)	Engineered core (dry)
Raw material input	Glass (E, H), carbon (12–50k), aramid, flax, basalt	Glass (E)+PP/RC	Glass (E)+PP/RC	PU foam + glass (E)
Fiber processing	Straight fibers	Straight fibers	CSM*	3D bridges
Structure	Unidirectional/bidirectional	Multiaxial	CSM/PP/CSM	–
Fiber orientation	0°/90°	-22.5° to +22.5°	various	–
Number of layers	1 (UD) or 2 (BD)	2–5	3	–

PRODUCT FINISHING

Self-adhesive – with SAERfix adhesive	Yes	Yes	Yes	Yes
Powder binder for preforms	Yes	Yes	No	No
Integrated fire protection – LEO	Yes	Yes	Yes	Yes
Integrated flow aid – SAERflow version	Yes	Yes	No**	No
Cutting & kitting	Yes	Yes	Yes	Yes
Toughening	Yes	Yes	Yes	No

Special items	EasyDrape; Magic Flow; Steady Plus; UltraFatigue	Carbon Class A Biax	+ NCF (SAERcore MAX)	Drapable
---------------	--	---------------------	----------------------	----------

RECOMMENDED FOR THE FOLLOWING PROCESSES

Vacuum infusion	+++	+++	++	+++
HP-RTM	+++	+++	+	–
RTM light	++	++	+++	+++
Compression	++	++	+++	++
Hand lay-up	+	+	–	–
Pultrusion	+++	++	–	–
Prepreg/continuous	+++	++	–	+

* Chopped Strand Mat | ** PP core available as flow medium as standard, alternatively recycled core material (RC)

SELECTION OF OUR NON-CRIMP FABRICS

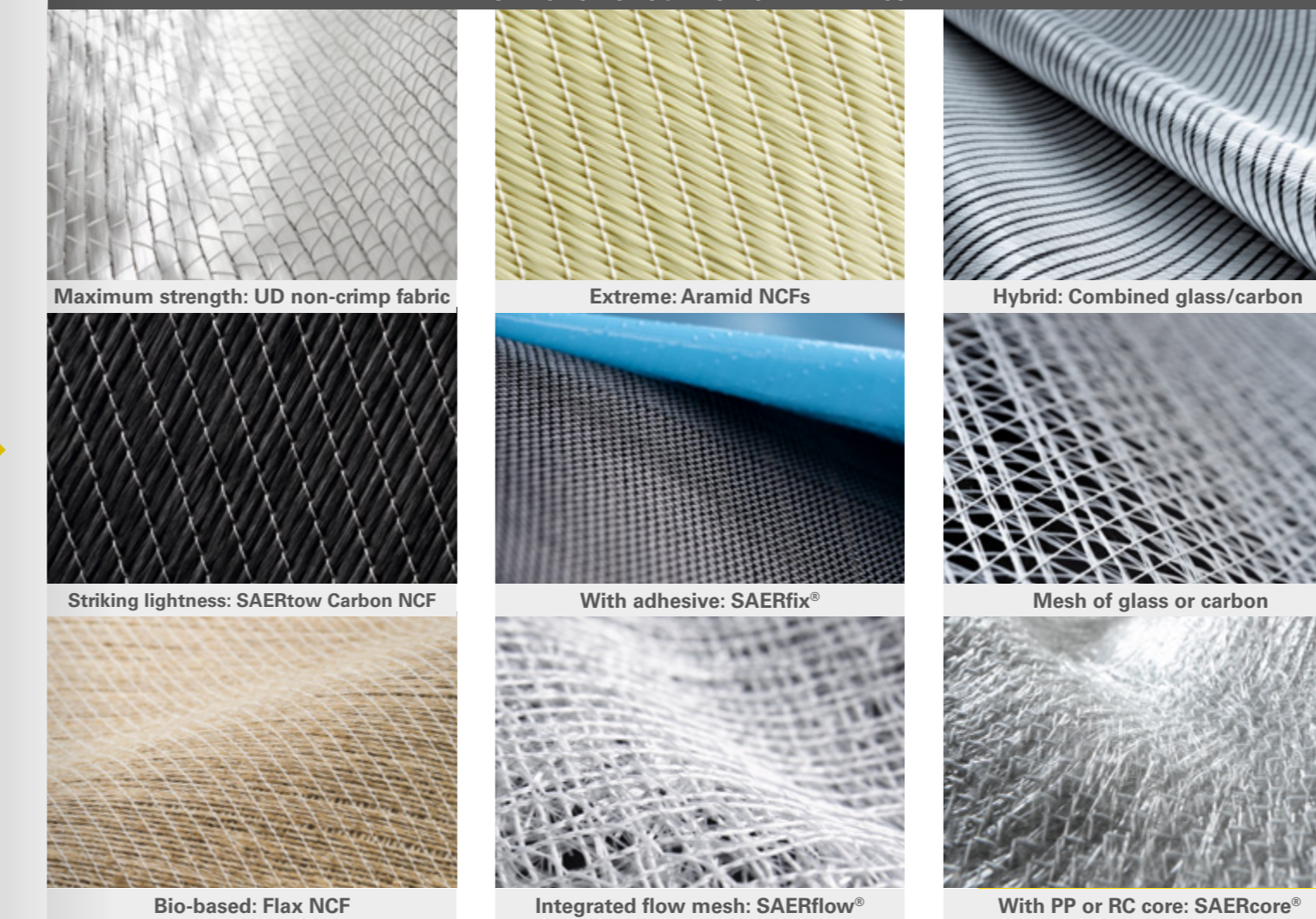

Maximum Customer-specific:

Whether fiber type, area weight, sewing, orientation or finishing: our products are individually configured for our customers and optimally adapted to various processes.

BASIC LINE

The SAERTEX Basic Line is our popular standard product range that offers short delivery times thanks to its availability from stock. The range comprises a portfolio of selected classic glass and carbon fiber fabrics together with SAERcore, SAERflow and SAERfix.

- 1 Cost Effective:**
Good products at a good price
- 2 Available From Stock:**
Fast and reliable delivery
- 3 Quality:**
Made by SAERTEX
- 4 Universally applicable:**
Our most popular items
- 5 Improved sustainability**



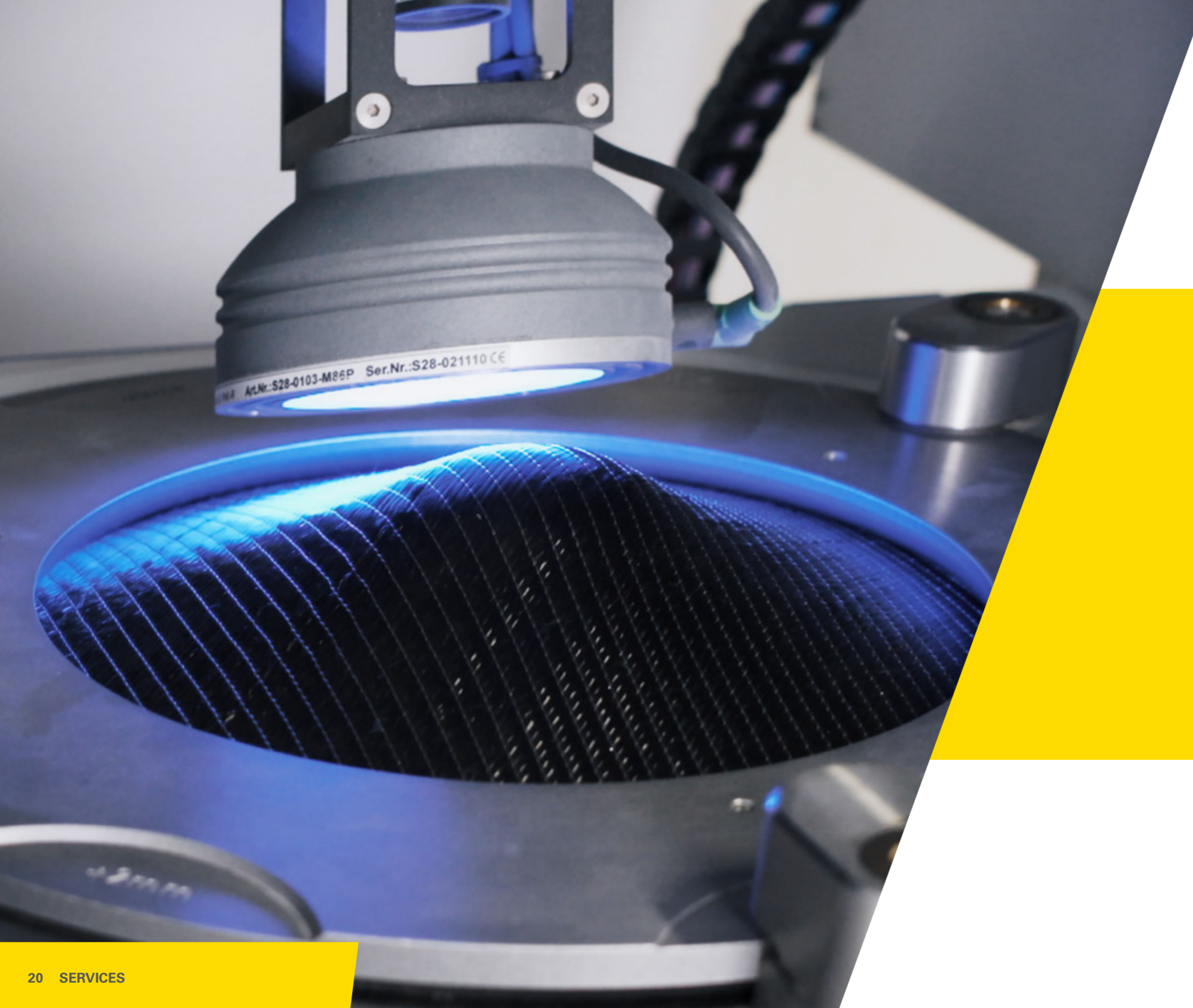

FROM THE IDEA TO THE PERFECT PRODUCT

It's as simple as: Present us with your idea – and we'll supply you with the right material to implement it. Our team dovetails with the links in your process chain in order to deliver reliable efficiency and progress at all levels



DISTRIBUTION

We are close to you: The global SAERTEX distribution network covers 50 countries. Our sales colleagues are specialized in your industry segment: From aerospace and automotive, to wind power and industry – we speak your language.



DEVELOPMENT

Success in series: We have developed over 3,333 different items for our customers in recent years. In the process, we combine individual requirements with our technological expertise. This quickly produces a concrete result – and the optimum product for you.



LABORATORY

Reliable values: Our in-house certified DNV-GL laboratory performs static tests such as tensile, bending and ILSS – and also covers areas such as material fatigue, fiber-resin content and NCF drapability. Our intensive quality controls enable us to develop the perfect material for you and accelerate development processes.



PRODUCTION

Everything under a single roof: Our Production department has its own engineering team and in-house metalworking shop for modifying the equipment and machines. This makes manufacturing your SAERTEX product economical, safe and fast. We rely on state-of-the-art manufacturing methods, including digital material inspection and role reports as well as our Smart Detect Control System for inner layer inspection.

SHORT ROUTES FOR YOUR SUPPLY CHAIN

SAERTEX is there to serve you throughout the world: We have eleven local production plants on five continents at which we manufacture our multiaxial non-crimp fabrics and core materials. Our unique supplier network allows over 80% of our sites to be supplied regionally. Furthermore, our comprehensive service and distribution network is available to you in 50 countries.

The Benefits to You:

- // Stable supply chains thanks to regional sourcing
- // Short transport routes: Reduced carbon footprint thanks to local supplies
- // Service: We are available locally and speak your language



11*
PRODUCTION
SITES WORLDWIDE



5
CONTINENTS



>80%
REGIONAL SOURCING
OF RAW MATERIALS

* Excluding SAERTEX multiCom®

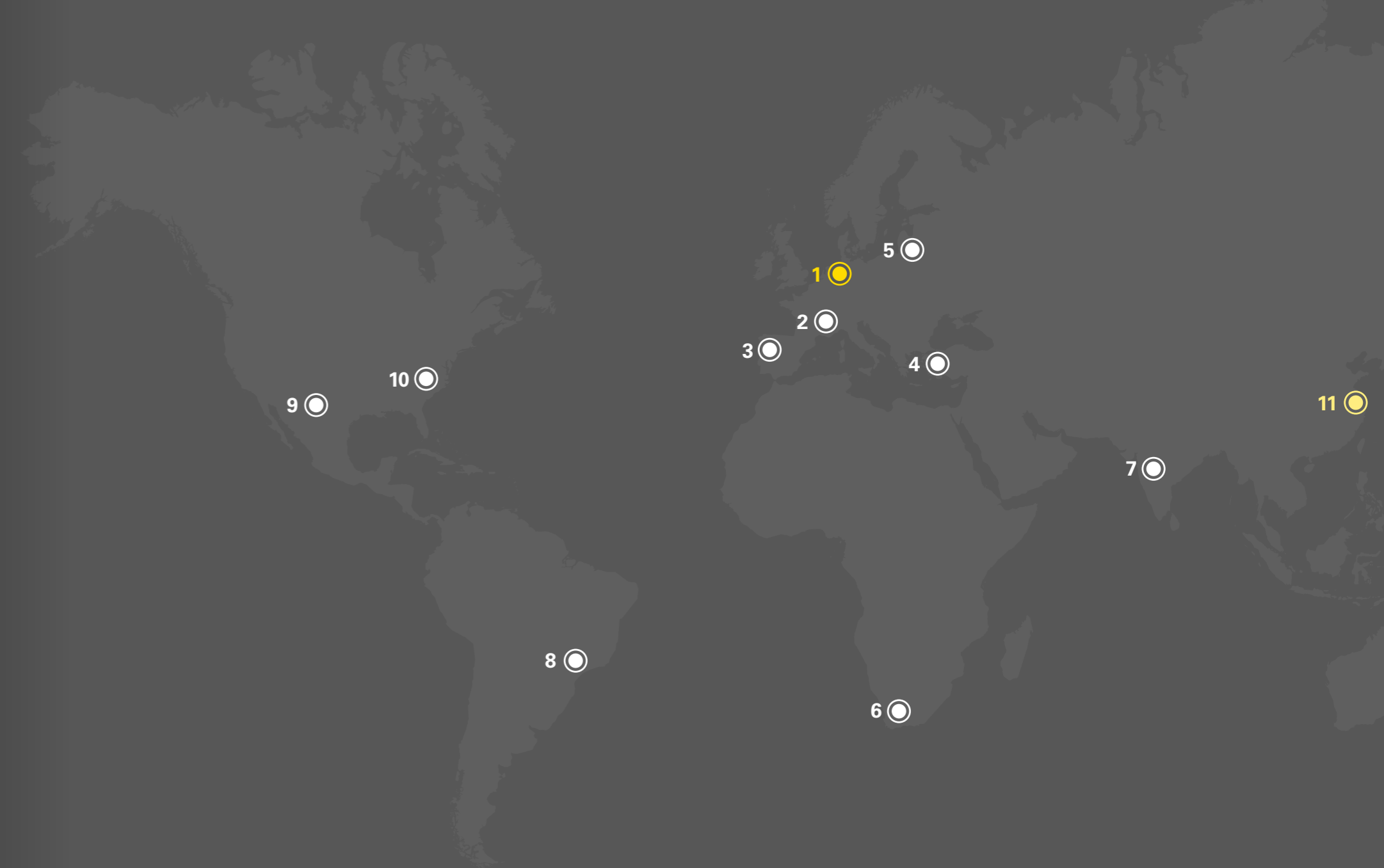

1. SAERTEX Germany Saerbeck | Headquarter
2. SAERTEX France
3. SAERTEX Portugal

4. SAERTEX Turkey
5. SAERTEX Baltics
6. SAERTEX South Africa

7. SAERTEX India
8. SAERTEX Brazil
9. SAERTEX Mexico

10. SAERTEX USA
11. SAERTEX China – coming soon

IT ALL STARTS WITH A CLEAR VISION

SAERTEX – INNOVATION FOR A RESOURCE-SAVING FUTURE

Sustainable engineering is the foundation of our future – and for SAERTEX already the goal. Our primary focus is to minimize weight and maximize the service life of components. Both requirements are implemented at the highest level in lightweight structures made with SAERTEX materials. For example, by replacing conventional materials such as steel and aluminum with modern fiber composites – step by step.

As a responsible company, we are continuously working to optimize our carbon footprint in the long term. We have already successfully implemented many measurable improvements for you. The future can come with SAERTEX!



EXEMPLARY SUSTAINABILITY AT OUR SAERBECK SITE:

// **Ökoprofit certification** since 2009, **ISO 14001 certification** since 2023, and **EcoVadis**-certified since 2024

// Generation of **green electricity: ø 3.2 m kWh per annum** through photovoltaic systems on the plant roofs

// **Promotion of the Jobrad cycle leasing model**

// **Sustainable supply chains:** **60% of our suppliers** are certified to **ISO 14001**

// **Waste reduction through recycling and optimization:**

/ **5,000 tons of recycled fiber waste** in the last 5 years
/ **66% less critical waste** within one year (2022–2023)

/ **16% total waste reduction** in the same period

RETHINK! RECYCLE!

Generating production waste during the manufacture of fabrics made of glass, carbon and aramid fibers is unavoidable. However, we actively seek to avoid wastage. We do not consider such residues to be waste, but a valuable raw material. Recycling is therefore a central component of our commitment to greater sustainability.

RECYCLING OF CARBON FIBER NON-CRIMP FABRICS WITH WIPAG: COLLECT

To ensure that new products are created from the recyclable materials we have established fixed process sequences. The recyclable materials are collected, sorted and further processed using various industrial processes. In this way new, high-quality products for the automotive or sports industries are created.



To video



Fiber residues are extracted during the ongoing production process.

SORT



Sorting by yarn, fibers or textile fabrics.

PREPARE

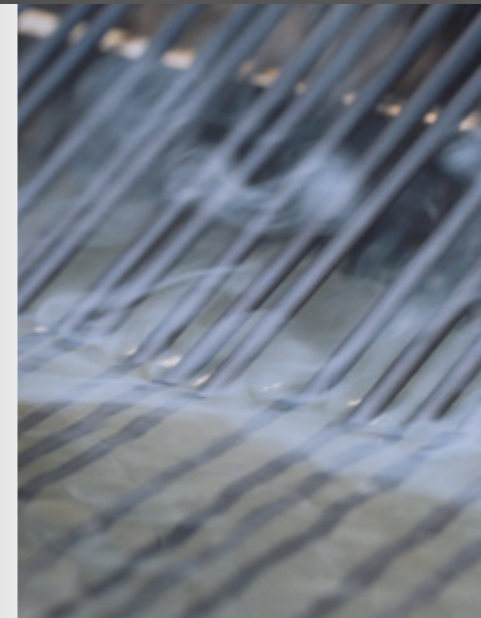

Established processes for glass and carbon fiber residues.

GRANULATE



Example –WIPAG: thermoplastic compound (PP or PA) with 10 to 40 % carbon fiber content.

END PRODUCT



These include automotive fittings and snowboard bindings, for instance.

REINFORCING YOUR IDEAS



Current references and videos showcasing international applications can be found on our website at www.saertex.com and our LinkedIn channel.

Printing works: LUC GmbH | Ludgeristr. 13 | 59379 Selm | Germany